dynasys

Power For The Long Haul



Service and Repair Manual



These recommended service procedures are intended to support authorized Dynasys trained dealers and service personnel in the maintenance and servicing of Dynasys units.

These recommended service instructions apply to all class 8 OTR vehicles. Please note that any modifications to the truck could influence the serviceability of the Dynasys unit and/or methods used to service it. Depending on the version and vehicle equipment, changes in procedure and diagnosis may be required that are outside the scope of this manual. In any event, the directives in the service manual must be followed. Acknowledged engineering standards must also be observed when performing service and maintenance work.





Table of Contents

1.0 Definitions and Abbreviations	4	5.2.12 Air Filter Element and Assembly	10
2.0 Technical Assistance	4	5.2.13 Oil Filter Service	10
3.0 Additional Documentation	4	5.3 Electric Cooling Fans	11
4.0 Technical Information	4	5.3.1 Lower Cabinet Fan Replacement	11
4.1 Dimensions	4	5.3.2 Radiator Fan Replacement	11
4.2 Fluid Capacities & Types	4	5.4 Speed Sensor Service or Replacement	12
4.3 Technical Specifications	4	5.4.1 Speed Sensor Service	12
4.4 Maintenance Schedule	4	5.4.2 Speed Sensor Replacement	12
5.0 Enclosure, Engine and APU Components	4	5.5 120 VAC Circuit Breaker Replacement	12
5.1 Enclosure	4	5.6 Cover Safety Switch	12
5.1.1 Enclosure Parts Breakdown	4	5.7 Relay Replacement	13
5.1.2 Engine Mounting	5	5.8 Exhaust Manifold Gasket Replacement	13
5.2 Engine Components	6	5.9 Exhaust Pipe Assembly Removal	13
5.2.1 Starter Motor	6	5.10 Frame Flange Replacement	14
5.2.2 Generator Drive Belt Service	6	5.11 Muffler Replacement	14
5.2.3 Alternator Drive Belt Service	6	5.12 Tailpipe Replacement	14
5.2.4 Alternator Assembly	7	6.0 Electrical Schematics	15
5.2.5 Generator Assembly	7	6.1 APU Engine Harness	15
5.2.6 Radiator Assembly	8	6.2 Interconnect Harness to ECM	15
5.2.7 Radiator Hose Replacement	8	7.0 HVAC System	16
5.2.8 Coolant Bottle Replacement	8	7.1 General Service	16
5.2.9 Water Separator Filter Service or Assembly Replacement	9	7.2 Basic Functions	16
5.2.10 Fuel Filter Service or Assembly Replacement	9	7.3 Troubleshooting	16
5.2.11 Fuel Pump Replacement	10	7.4 Service Procedures	18
		7.5 Troubleshooting Flow Charts	21

1.0 Definitions and Abbreviations

- ▶ **APU** (Auxiliary Power Unit)
- ▶ **Class 8 Truck** (Heavy Duty Trucks over 33,000 pounds [15,000 kg] as defined by FHWA in the US)
- ▶ **CCU** (Cabin Control Unit)
- ▶ **ECM** (Engine Control Module)
- ▶ **FHWA** (Federal Highway Administration)
- ▶ **HVAC** (Heating, Ventilating, and Air Conditioning)
- ▶ **OTR** (Over the Road)

2.0 Technical Assistance

Before calling technical assistance please have ready:

- ▶ **Dynasys Serial Number**
- ▶ **Unit Hours**
- ▶ **In Service Date**
- ▶ **Dynasys Service Manual**

Technical support is available Mon-Fri 8:00 am – 5:00 pm CT by calling 512-225-0165 or 1-800-289-8282

3.0 Additional Documentation

- Dynasys Owners Manual, 2009 Model G1D
- Dynasys Installation Manual, Model G1D
- Yanmar; User’s Handbook
- Markon; AC Generator Installation, Service & Maintenance Manual

4.0 Technical Information

4.1 Dimensions

Main Unit	Bunk Heater/AC Unit
Width 18"	Width 11.50"
Height 27"	Height 12.50"
Depth 25"	Depth 22.25"
Weight 385 lb	Air Flow 12,000 BTU

4.2 Fluid Capacities & Types

Engine Oil w/filter	2.71/3US qt.
Type	API CJ-4
Viscosity	(See Chart Top Right)

SAE Viscosity Grade and Outdoor Temperature

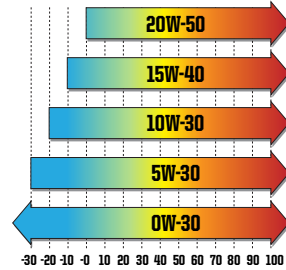

Cooling System	50/50 mixture of ethylene glycol & water
Air Conditioning	R134a; 2 lbs, 12 oz
Fuel Type	Diesel Fuel Only

4.3 Technical Specifications

Engine	Yanmar, 2-cylinder, liquid cooled
Output	12 hp / (8.8 kW) @2800 RPM
Alternator	55 Amps
Generator	Markon
Output	6 kW; 120 Volts [AC] / 60 hz
HVAC	Hermetic Compressor / Electric Heating
Output	12,500 BTU / 2.5 kW

4.4 Maintenance Schedule

See table on opposite page

5.0 Enclosure, Engine and APU Components

5.1 Enclosure

The Dynasys APU has five stainless steel panels that are fastened with ¼ -20 x ½" hex head bolts. The front access panel is attached to unit with four Southco latches.

5.1.1 Enclosure Parts Breakdown

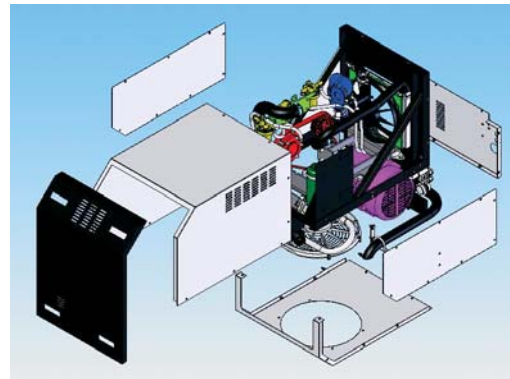

Enclosure Parts Breakdown



4.4 Maintenance Schedule

Each Trip *	At 50 Hrs Total	At 500 Hrs Total	Every 1,000 Hrs	Every 2,000 Hrs	Inspect/Service These Items
					ENGINE
✓	✓	✓	✓		Check engine oil level
✓	✓	✓	✓		Inspect belts, hoses for condition/tension
✓	✓	✓	✓		Check for unusual noise or vibration
			✓		Change air cleaner
	✓	✓	✓		Inspect water separator
				✓	Change fuel filter
				✓	Check adjust engine speed
				✓	Change engine coolant
					ENGINE OIL CHANGE INTERVALS
	✓		✓		Change oil (use CJ-4 oil) and filter
					ELECTRICAL
✓		✓	✓		Check cover safety switch
		✓	✓		Inspect battery terminals
		✓	✓		Inspect unit for broken or loose wires
		✓	✓		Check for loose connections
					MISC
✓	✓	✓	✓		Visually inspect for fluid leaks
✓	✓	✓	✓		Visually inspect for damaged/loose components
✓	✓	✓	✓		Check mounting bolts and brackets
			✓		Check/clean condenser coil and generator air inlet

5.1.2 Engine Mounting

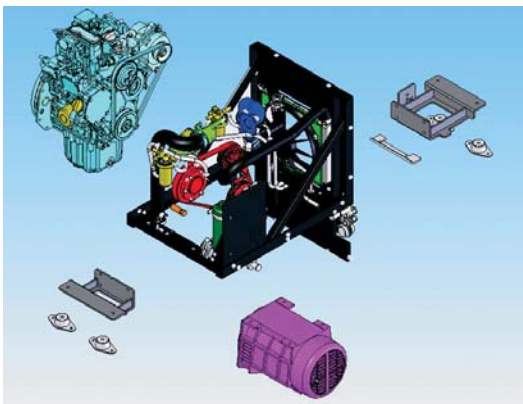

Engine Mounting Diagram

Front Bracket and Frame Isolators

1. Remove the front access cover and lower panels (the top cover can be removed also if the operator feels this would aid in the procedure).
2. Support engine with hydraulic jack at oil sump area.
3. Loosen Allen head bolts at block assembly.
4. Loosen hex head bolts at bracket to frame through bolts.
5. Remove bracket, remove frame isolator, and replace with new bracket or isolator.
6. Reverse procedure to complete installation; apply anti-seize compound to all stainless steel fasteners.
7. Prior to testing APU, verify that all connections and fasteners are secure.

Rear Bracket and Frame Isolators

1. Remove the front access cover, top, lower, and rear panels.
2. Support engine with hydraulic jack at oil sump area.
3. Loosen Allen head bolts at block assembly.
4. Loosen hex head bolts at bracket to frame through bolts.
5. Remove generator front lower bracket bolts and bracket assembly; retain for reinstallation.
6. Loosen alternator top adjusting bolt, swing alternator towards engine assembly for clearance of radiator, remove radiator mounting stud nuts at rear of APU frame and pull radiator module towards engine assembly.
7. Remove rear frame-to-bracket through bolts; retain for reinstallation.
8. Remove bracket and frame isolator; then replace with new bracket or isolator.
9. Reverse procedure to complete installation; apply anti-seize compound to all stainless steel fasteners.
10. Prior to testing APU, verify that all connections and fasteners are secure.

Required Tools

- Allen head bolts – 8 mm hex key
- Bracket through bolts – 14 mm socket and wrench
- Front generator lower bracket – 14 mm socket and wrench
- Frame isolator – 13 mm socket and wrench
- Cover panels – 7/16 socket

► **5.2 Engine Components**

Each Dynasys unit is supplied with an authorized Yanmar Service Manual. Refer to manual and Yanmar tech support BEFORE performing any engine component repair, service or replacement.

► **5.2.1 Starter Motor**

1. Disconnect 12 volt power from the APU by removing the 125 amp fuse located at the truck's main battery box.
2. Remove front and top panels.
3. Disconnect positive cable at starter assembly.
4. Remove top starter mounting bolt and nut; retain for reinstallation.
5. Remove lower starter nut, leaving bolt in flywheel flex plate assembly.
6. Remove starter by sliding to the right from lower bolt in flex plate.
7. Reverse procedure to complete installation.
8. Recheck all connections and re-install 125 amp fuse.

Required Tools

- Top panel - 7/16" wrench
- Positive connection at starter post - 13 mm socket or 13 mm wrench
- Upper and lower starter bolts and nuts - 17mm socket and 17 mm wrench

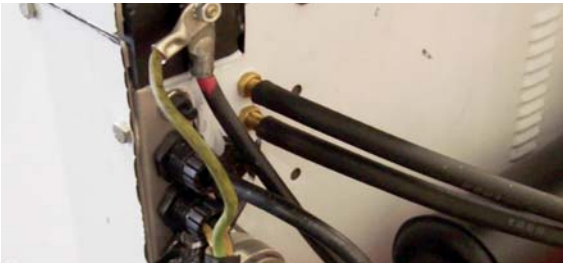

Starter Motor

► **5.2.2 Generator Drive Belt Service**

1. Remove front access, top, and left lower side panels.
2. Insert 3/8 drive ratchet into tensioner arm.
3. Release belt tension and remove belt.
4. Removal of belt from unit can be achieved by slipping belt through frame and crank pulley face.
5. Reinstall by reversing procedure.
6. Prior to testing APU, visually check belt alignment to insure proper belt and pulley(s) mating.

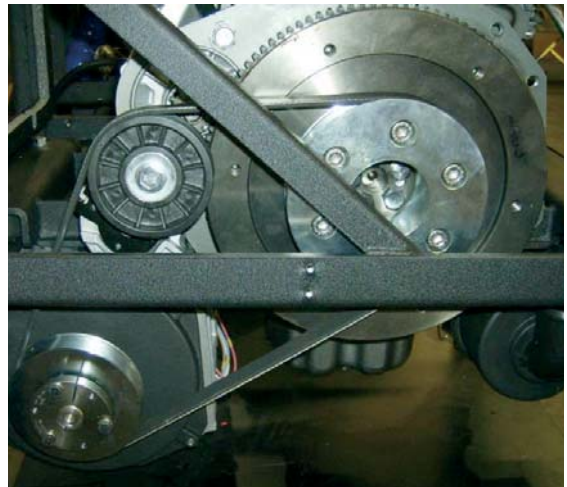

Generator Drive Belt

Required Tools

- Generator belt tensioner - 3/8 drive ratchet and extension

► **5.2.3 Alternator Drive Belt Service**

1. Remove front access and top panels.
2. Loosen top alternator adjusting bolt.
3. Loosen lower pivot bolt.
4. Slide alternator assembly towards engine to relieve belt tension.
5. Remove alternator belt and replace with new belt.
6. Insert small pry bar between engine lift bracket and top area of alternator assembly to gently slide alternator along adjustment arm.
7. Reverse procedure to complete installation.
8. Prior to testing APU, verify proper belt tension and alignment and all connections.

Required Tools

- Top alternator adjusting bolt - 12mm socket or 12 mm wrench
- Lower alternator pivot bolt - 14mm socket or 14 mm wrench
- Alternator adjustment - small pry bar



Alternator Drive Belt

5.2.4 Alternator Assembly

1. Disconnect APU ground cable and 120 VAC ground cable. They are on the same eyelet located on the exterior at the back of the APU Engine Cabinet. (see picture at 5.2.1)
2. Remove front and top access panels.
3. Disconnect positive post terminal and field connector on alternator.
4. Loosen top alternator adjusting bolt.
5. Relieve belt tension by sliding assembly towards engine; remove belt.
6. Remove lower alternator pivot bolt.
7. Remove top alternator adjusting bolt.
8. Remove alternator assembly.
9. Reverse procedure to complete installation.
10. Prior to testing unit, verify that all connections are secure and alternator belt tension is correct.

Required Tools

- Ground cable connection at frame stud - 7/16 socket
- APU access panels - 7/16 socket
- Top alternator adjusting bolt - 12 mm socket
- Lower alternator pivot bolt - 14 mm socket or 14 mm wrench
- Alternator positive stud - 10 mm socket or 10 mm wrench

5.2.5 Generator Assembly

1. Disconnect APU ground cable and 120 VAC ground cable. They are on the same eyelet located on the exterior at the back of the APU Engine Cabinet. (see picture at 5.2.1)
2. Remove front access, top, rear, and left lower side panels.
3. Loosen rear panel and let hang from rear of APU. (see top picture on right)
4. Insert 3/8 drive ratchet into tensioner manual adjustment point.
5. Release belt tension and remove belt.

6. Should belt replacement be necessary, removal of belt from unit can be achieved by slipping belt through frame and crank pulley face.
7. Support generator with hydraulic jack.
8. Loosen and remove nuts at rear of generator assembly; retain nuts for reinstallation.
9. Remove front generator bracket; retain bracket, bolts, and nuts for reinstallation.
10. Disconnect generator lead eyelet at circuit breaker.
11. Disconnect generator from 120 VAC Sure Seal connection.
12. Lower generator from APU; retain generator/frame spacers located at the rear of the generator for reinstallation.
13. Loosen Allen head set screw at QD bushing shaft key area prior to attempting removal of QD bushing from generator shaft. (see lower left picture on page 15).
14. Removal of the pulley from the old generator is performed in the following manner: swap the 3 bolts from the threaded holes in the pulley to the threaded holes in QD bushing. As bolts are tightened, place a large flat head screwdriver between the front face of the pulley and the rear of the QD bushing. This allows the taper lock to be released from the pulley (see lower right picture below).
15. Reinstall generator pulley and QD bushing, using Dynasys tool #55-1010. This ensures proper generator belt alignment.
16. Reverse procedure to complete installation.
17. Prior to testing APU, verify that all connections are secure and belts are properly aligned.



Generator Assembly

Required Tools

- Ground cable connection at frame stud - 7/16 socket
- APU access panels - 7/16 socket
- Circuit Breaker retaining nut - grip pliers
- Generator belt tensioner - 3/8 drive ratchet or 3/8 drive breaker bar

- ▶ Generator front bracket - 14 mm socket and 14 mm wrench
- ▶ Circuit breaker terminal connection - flat head screwdriver
- ▶ Generator rear bracket - 14 mm wrench (x2)
- ▶ Generator QD bushing set screw - 5/32 hex key
- ▶ Generator QD bushing mounting bolts - 7/16 socket, large flathead screwdriver.
- ▶ Generator belt alignment - Dynasys tool #55-1010

▶ 5.2.6 Radiator Assembly

1. Remove front and top access panels.
2. Disconnect ground at rear of APU.
3. Loosen top alternator adjusting bolt.
4. Loosen lower alternator pivot bolt.
5. Relieve belt tension by sliding alternator assembly towards engine. This allows clearance for removal of radiator module assembly.
6. Drain coolant from cooling system by attaching coolant recovery system inlet at filler neck. Remove and retain all coolant.
7. Disconnect radiator fan pigtail, located at right side center area of APU frame.
8. Remove inlet and outlet radiator hoses at radiator header; move to the side for ease of radiator module removal from frame.
9. Remove radiator mounting stud nuts (3) located at rear of APU; retain for reinstallation.
10. Remove module from frame, avoiding rear frame insulation and module studs.
11. Drain any remaining coolant from radiator.
12. Remove shroud assembly bolts (4) from radiator; retain bolts for reinstallation.
13. Reverse procedure for reinstallation
14. Prior to testing APU, verify that all connections and fasteners are secure and that coolant is at proper level



Radiator Assembly

Required Tools

- ▶ APU access panels - 7/16 socket
- ▶ Ground cable at frame stud - 7/16 socket or 7/16 wrench
- ▶ Top alternator adjusting bolt - 12 mm socket
- ▶ Lower alternator pivot bolt - 14 mm socket or 14 mm wrench
- ▶ Coolant recovery system
- ▶ Radiator frame mounting stud nuts - 7/16 socket or 7/16 wrench
- ▶ Radiator hose connections - 5/16 nut driver or 5/16 socket

▶ 5.2.7 Radiator Hose Replacement

1. Remove front and top access panels.
2. Attach coolant recovery system to coolant filler neck; drain coolant and retain.
3. Remove radiator hose; retain clamps and radiator header 28mm collar for reinstallation.
4. Reverse procedure for reinstallation.
5. Prior to testing APU, verify that all connections are secure and coolant is at proper level.



Radiator Hose Replacement

Required Tools

- ▶ APU access panels - 7/16 socket
- ▶ Coolant recovery system
- ▶ Radiator hose clamps - 5/16 nut driver or 5/16 socket

▶ 5.2.8 Coolant Bottle Replacement (For S/N: 61D-10037 and lower)

1. Remove front access cover.
2. Loosen lower bottle clamp to allow bottle to slide upwards.
3. Loosen upper bottle clamp; open clamp to allow bottle to be removed without removing clamp completely from panel.
4. Disconnect switch pigtail located at lower frame area below bottle assembly.
5. Reverse procedure to complete reinstallation.
6. Prior to testing APU, verify that all connections and fasteners are secure.

Required Tools

- ▶ Coolant bottle clamps - 5/16 nut driver or 5/16 socket



Coolant Bottle Replacement



5.2.8a Coolant Bottle Replacement (For S/N: 61D-10038 and higher)

- Remove front access cover.
- Remove the two 5/16" nuts located on the side and top of the bottle.
- Slide the bottle off of the studs.
- Disconnect switch pigtail located at lower frame area below bottle assembly.
- Reverse procedure to complete reinstallation.
- Prior to testing APU, verify that all connections and fasteners are secure.

Required Tools

- Coolant bottle nuts - 7/16" nut driver or 7/16" socket

5.2.9 Water Separator Filter Service or Assembly Replacement

Water Separator Service Procedure

1. Remove front access panel, remove top cover, and turn fuel level to 'off' at fuel filter and water separator.
2. Remove fuel bowl collar to allow for access of filter element; remove fuel bowl section. Retain collar and body gasket for reinstallation.
3. Clean or replace element.
4. Reverse procedure for reinstallation.
5. Prior to testing APU, verify that all connections are secure and fuel levers are returned to the 'on' position.



Water Separator

Water Separator Replacement Procedure

1. Remove front access panel, remove top cover, and turn fuel level to 'off' at fuel filter and water separator.
2. Disconnect fuel lines at water separator assembly.
3. Remove bracket assembly through bolt; retain bolt and nut for reinstallation.
4. Remove assembly.
5. Reverse procedure for reinstallation.
6. Prior to testing APU, verify that all connections are secure and fuel levers are returned to the 'on' position.

Required Tools

- Fuel line clamps - grip pliers
- Water separator through bolt - 12 mm socket and 12 mm wrench

5.2.10 Fuel Filter Service or Assembly Replacement

Service Procedure

1. Remove front access panel and turn fuel level to 'off' at fuel filter and water separator.
2. Remove fuel bowl collar to allow access to filter element; remove fuel bowl section. Retain collar and body gasket for reinstallation.
3. Replace element.
4. Reverse procedure for reinstallation.
5. Prior to testing APU, verify that all connections are secure and fuel levers are returned to the 'on' position.

Replacement Procedure

1. Remove front access panel and turn fuel level to 'off' at fuel filter and water separator.
2. Disconnect fuel lines at fuel filter assembly.
3. Remove bracket assembly through bolt; retain bolt and nut for reinstallation. Remove assembly.
4. Reverse procedure for reinstallation.
5. Prior to testing APU, verify that all connections are secure and fuel levers are returned to the 'on' position.



Fuel Filter

Required Tools

- Fuel line clamps - grip pliers
- Fuel filter through bolt - 12 mm socket
- Fuel filter rear nut - 13 mm wrench

5.2.11 Fuel Pump Replacement

1. Remove front access panel, remove top cover, and turn fuel level to 'off' at fuel filter and water separator.
2. Disconnect fuel lines at fuel pump assembly and pigtail connector.
3. Remove fuel pump mounting bolts (2); remove assembly from bracket.
4. Reverse procedure for reinstallation.
5. Prior to testing APU verify that all connections are secure and fuel levers are returned to the 'on' position.

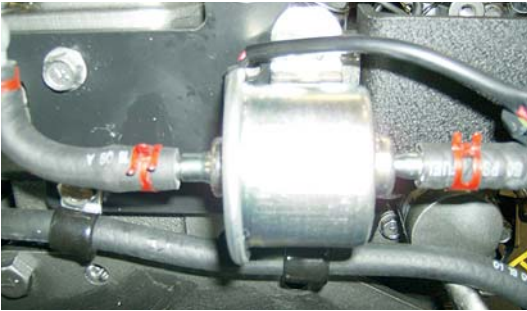

Fuel Pump Replacement

Required Tools

- Fuel line clamps - grip pliers
- Fuel pump mounting bolts - 11 mm socket

5.2.12 Air Filter Element and Assembly

Service Procedure

1. Remove front access panel.
2. Detach assembly front cover by releasing snaps (2) to allow access to filter element.
3. Remove element; replace with new filter.
4. Reverse procedure for reinstallation.
5. Special care should be used when realigning Air Cleaner front cover with body assembly; housing may be damaged if misaligned.

Replacement Procedure

1. Remove front and left lower access panels.
2. Detach assembly front cover by releasing filter assembly snaps (2), allowing removal of housing.
3. Remove air cleaner bracket lower bolt to allow release of cleaner assembly from bracket.
4. Slide assembly towards the left for complete removal without damaging bracket assembly.
5. Reverse procedure for reinstallation.
6. Special care should be used when realigning Air Cleaner front cover with body assembly; housing may be damaged if misaligned.
7. Prior to testing APU, verify that all connections and fasteners are secure.



Air Filter Element

Required Tools

- Lower Air Cleaner Bracket bolt - 13 mm socket and 13 mm wrench

5.2.13 Oil Filter Service

1. Remove front access panel.
2. Drain oil from engine using provided clear drain hose attached to ball valve located at lower right side of oil sump area.
3. Remove oil filter from block assembly; support filter with shop towel to prevent excessive oil leakage.
4. Apply thin coat of oil onto new oil filter sealing O-ring; hand tighten oil filter to block assembly; remove all excess oil.
5. Ensure ball valve is in the 'closed' position; refill oil to proper level.
6. Prior to releasing unit back to customer, perform short run test, and recheck oil level and proper filter sealing.



Oil Filter

Required Tools

- Oil filter – end cap or pliers handle oil filter wrench
- Used oil – approved receptacle



5.3 Electric Cooling Fans

The Dynasys APU has two electric fans. The function of the lower fan (pusher fan) is to evacuate the APU cabinet box. This fan is protected by an outside panel rock guard attached directly through the bottom panel to the fan assembly. The function of the upper fan (puller fan) is to bring air into the APU cabinet and across the radiator module. This fan is attached to the radiator shroud assembly. The air flow direction of these fans is critical for proper APU function.

5.3.1 Lower Cabinet Fan Replacement

1. Remove front and right side lower access panels.
2. Disconnect fan harness pigtail located at lower area of APU frame rail.
3. Remove the attaching through bolts (4) located on the outside of lower panel, using a backup wrench at nuts on the fan assembly; retain all hardware for reinstallation.
4. Remove rock guard and fan assembly.
5. Reverse procedure for reinstallation.
6. Prior to testing APU, verify that all connections and fasteners are secure.

Required Tools

Access panels - 7/16 socket or 7/16 wrench

Lower fan assembly through bolts - 7/16 socket and 7/16 wrench



Lower Cabinet Fan

5.3.2 Radiator Fan Replacement

1. Remove front and upper access panels.
2. Disconnect ground cable at rear of APU.
3. Disconnect fan harness pigtail located at lower area of APU frame rail towards radiator assembly.
4. Loosen top alternator adjusting bolt and lower pivot bolt.
5. Relieve belt tension by sliding alternator assembly towards engine, allowing for removal of fan assembly.
6. Remove fan assembly mounting nuts (4) from radiator shroud studs; retain for reinstallation.
7. Removal of fan assembly is achieved by sliding unit off shroud studs and lifting fan up between radiator hoses.
8. Reverse procedure for reinstallation.
9. Prior to testing APU, verify that all connections and fasteners are secure.

Required Tools

- Upper access panel - 7/16 socket or 7/16 wrench
- Ground cable at frame stud - 7/16 socket
- Top alternator adjusting bolt - 12 mm socket or 12 mm wrench
- Lower alternator pivot bolt - 14 mm socket or 14 mm wrench
- Alternator adjustment - small pry bar



Radiator Fan

5.4 Speed Sensor Service or Replacement

The Dynasys Speed Sensor is mounted through the Yanmar flex-plate and is located at the front of the APU. The sensor gap between the sensor tip and ring gear is set at .050" or 1.27 mm. Should intermittent engine shut off be experienced with a 'low-rpm' error message, check for debris buildup at sensor tip or excessive gap between the ring gear and sensor tip. Shut down engine to perform cleaning or adjustment.

5.4.1 Speed Sensor Service

1. Remove front access panel.
2. Check for debris at sensor tip and proper gap between sensor tip and ring gear area. Factory setting is at .050" or 1.27 mm.
3. Remove any debris by using a controlled spray of shop air.
4. Adjustment is achieved by loosening retaining nut at rear of flex-plate mounting and turning sensor closer to or farther from ring gear.
5. Verify gap by using feeler gage (preferably non-magnetic) while tightening retainer nut.
6. Prior to testing APU, verify that all connections and fasteners are secure.

5.4.2 Speed Sensor Replacement

1. Remove front access panel.
2. Disconnect cover switch pigtail located at APU lower frame area near coolant bottle.
3. Loosen coolant bottle clamps to allow bottle to slide upwards. (For S/N GD-10038 and higher this step is not required.)
4. Remove (2) cover switch mounting screws and nuts; retain for reinstallation.
5. Reverse procedure to complete reinstallation.
6. Prior to testing APU, verify that all connections and fasteners are secure.

Required Tools

- ▶ Coolant bottle clamps - 5/16 nut driver or 5/16 socket
- ▶ Safety switch - Phillips head screwdriver and 7/32 wrench or socket.



Speed Sensor

5.5 120 VAC Circuit Breaker Replacement

1. Disconnect ground at rear of APU.
2. Remove front and right lower side access panels.
3. Remove outside circuit breaker, retaining jam nut.
4. Removal of breaker assembly is achieved by pulling breaker away from panel.
5. Remove breaker protector boot.
6. Remove terminal screws from breaker.
7. Reverse procedure to complete reinstallation.
8. Prior to testing APU, verify that all connections and fasteners are secure.

Required Tools

- ▶ Right side access panel - 7/16 socket or 7/16 wrench
- ▶ Ground cable at frame stud - 7/16 socket or 7/16 wrench
- ▶ Circuit breaker jam nut - grip pliers
- ▶ Circuit breaker terminal screws - med flat head screwdriver



VAC Circuit Breaker

5.6 Cover Safety Switch

1. Remove front access panel.
2. Disconnect cover switch pigtail located at APU lower frame area near coolant bottle.
3. Loosen coolant bottle clamps to allow bottle to slide upwards.
4. Remove (2) cover switch mounting screws and nuts; retain for reinstallation.
5. Reverse procedure to complete reinstallation.
6. Prior to testing APU, verify that all connections and fasteners are secure.

Required Tools

- ▶ Coolant bottle clamps - 5/16 nut driver or 5/16 socket
- ▶ Safety switch - Phillips head screwdriver and 7/32 wrench or 7/32 socket



Cover Safety Switch



5.7 Relay Replacement

1. Remove front and upper access panels.
2. Disconnect molded pigtail at relay base.
3. Remove relay mounting tab nut from panel stud. Removal of coolant bottle is recommended for replacing relays #2 and #4.
4. Reverse procedure to complete reinstallation.
5. Prior to testing APU, verify that all connections and fasteners are secure.

Required Tools

- Relay mounting tab nut - 7/16 socket or 7/16 wrench
- Coolant bottle clamps (optional) - 5/16 nut driver or 5/16 socket



Relay Replacement

5.8 Exhaust Manifold Gasket Replacement

1. Remove front and upper access panels.
2. Remove flange nuts and lock washers; retain for reinstallation.
3. Pull exhaust pipe assembly away from manifold.
4. Remove old gasket; replace with new.
5. Reverse procedure to complete reinstallation.
6. Prior to testing APU, verify that all connections and fasteners are secure.

Required Tools

- Access panel - 7/16 socket or 7/16 wrench
- Exhaust manifold nuts - 13 mm socket or 13 mm wrench



Exhaust Manifold

5.9 Exhaust Pipe Assembly Removal

1. Remove front and upper access panels.
2. Push exhaust temp sleeve in downward direction to allow access to lower exhaust clamp.
3. Loosen lower exhaust clamp; let clamp slide down to clear exhaust pipe.
4. Remove exhaust manifold flange nuts and lock washers; retain for reinstallation.
5. Pull upper exhaust flange away from manifold; lift exhaust pipe assembly from frame.
6. Reverse procedure to complete reinstallation.
7. Prior to testing APU, verify that all connections and fasteners are secure.

Required Tools

- Upper access panel - 7/16 socket or 7/16 wrench
- Lower exhaust pipe clamp - 1/2 socket or 1/2 wrench
- Exhaust manifold nuts - 13 mm socket or 13 mm wrench

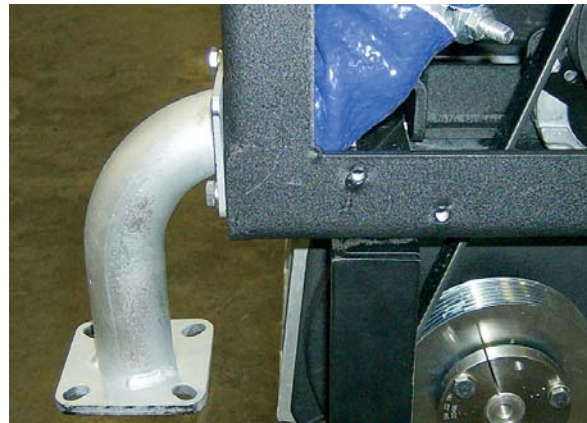

Exhaust Pipe Assembly

► **5.10 Frame Flange Replacement**

1. Remove front and upper access panels.
2. Push exhaust temp sleeve in downward direction to allow access to lower exhaust clamp.
3. Loosen clamp and slide in an upwards direction to clear frame flange inlet.
4. Remove muffler-to-flange bolts and nuts (4); retain for reinstallation. Let muffler hang, supported by tailpipe hanger.
5. Remove flange-to-frame bolts and lock washers (2); retain for reinstallation.
6. Remove frame flange assembly; replace with new flange and gasket.
7. Reverse procedure to complete reinstallation.
8. Prior to testing APU, verify that all connections and fasteners are secure.

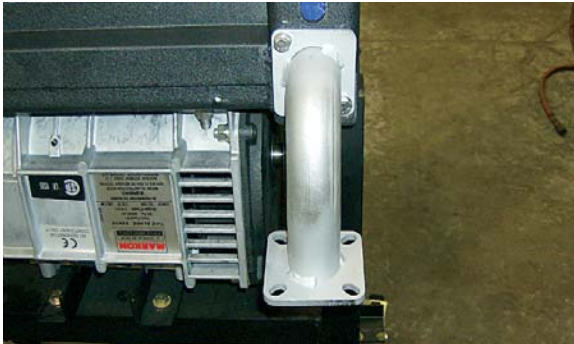

Frame Flange Replacement

Required Tools

- Upper access panel and rear frame flange – 7/16 socket or 7/16 wrench
- Lower exhaust pipe clamp – ½ socket or ½ wrench

► **5.11 Muffler Replacement**

1. Remove front access cover.
2. Loosen nuts at lower frame flange assembly; retain for reinstallation.
3. Remove tailpipe hanger clamp assembly; retain for reinstallation.
4. Slide tailpipe away from muffler outlet.
5. Remove muffler assembly and flange gasket.
6. Install new flange gasket and muffler assembly.
7. Reverse procedure to complete reinstallation.
8. Prior to testing APU, verify that all connections and fasteners are secure.



Muffler Replacement

Required Tools

- Frame muffler flange nut – ½ socket and ½ wrench
- Tail pipe hanger clamp – ½ socket or ½ wrench

► **5.12 Tailpipe Replacement**

1. Remove front access panel.
2. Remove tailpipe support clamp at right side of APU; retain for reinstallation.
3. Remove tailpipe hanger nuts; retain for reinstallation.
4. Remove tailpipe by sliding tailpipe inlet away from muffler outlet connection.
5. Replace with new tailpipe assembly.
6. Reverse procedure to complete installation.
7. Prior to testing APU, verify that all connections and fasteners are secure.

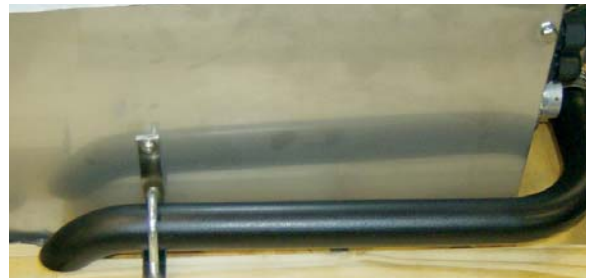

Tailpipe Replacement

Required Tools

1. Tailpipe support clamp nuts - ½ socket or ½ wrench
2. Tailpipe hanger clamp



6.0 Electrical Schematics

The following two diagrams (right) are provided to assist in electrical diagnosis. This information is current to the publish date of this manual. Refer to the Dynasys web site for any revisions of electrical system.

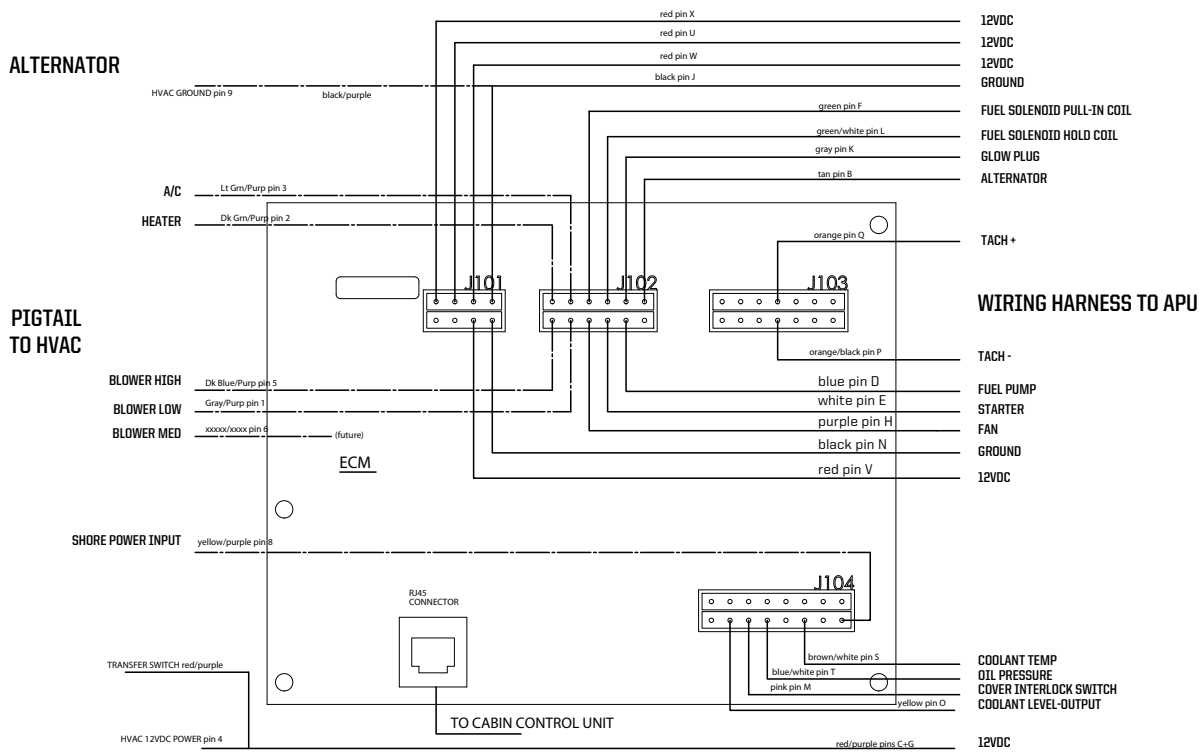
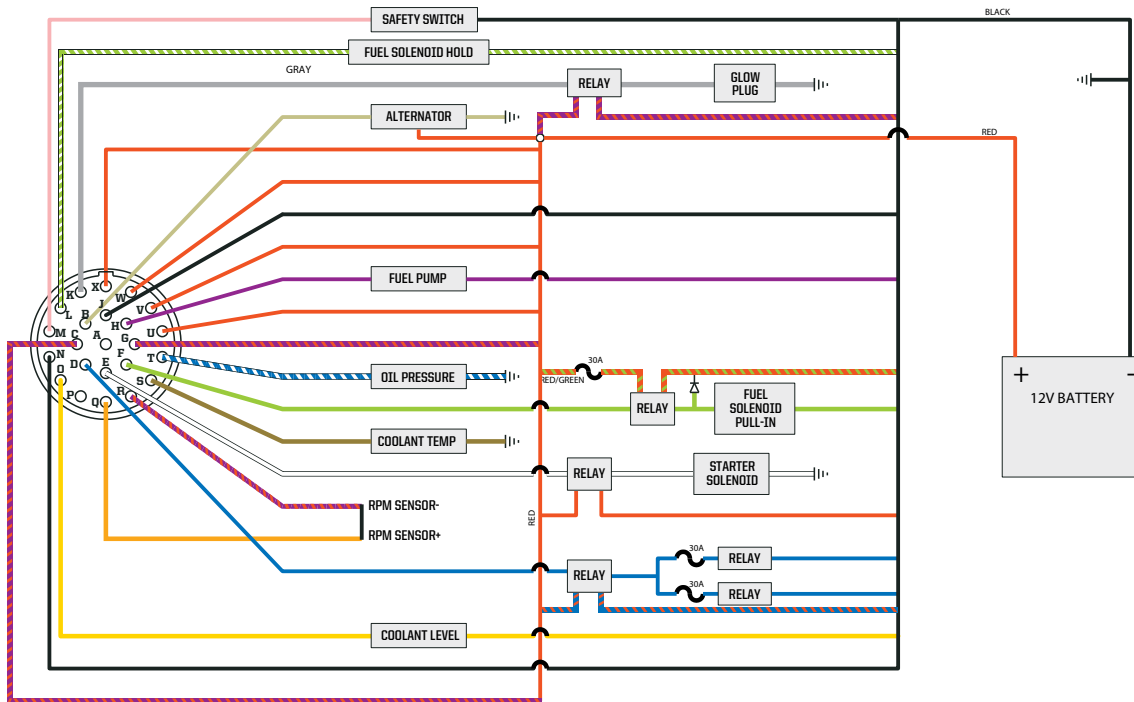

7.0 HVAC System

The Dynasys air conditioner is fully automatic. A constant comfort zone is maintained with the temperature set point. The Dynasys air conditioner is a 12,500 BTU Hermetic R134a system that is not integrated into the truck's air conditioning system. When cooling mode is selected and the Dynasys is in operation, the compressor is activated (installed under the bunk). The blower motor circulates internal cab air across the evaporator coil, releasing cool air into the bunk area. This system is designed to maximize bunk cooling efficiency.

WARNING: Only certified R134a air conditioning technicians should service the Dynasys air conditioner system.

The Dynasys heating system is fully automatic. A constant comfort zone is maintained with the temperature set point. The bunk heating system has a capacity of 8,536 BTUs (2.5kw). This is a complete stand-alone system that is not integrated into the truck's heating system. When heating mode is selected and the Dynasys is in operation, the electric heat element(s) are energized (installed under the bunk). The blower motor circulates internal cab air across the heating element(s), releasing warm air into the bunk area. This system is designed to maximize bunk heating efficiency.

7.1 General Service

Dynasys recommends a monthly inspection and/or cleaning of the HVAC inlet filter screen (part #55-8168). This will insure odor free air delivery inside bunk and maximum evaporate core performance. The process for removal and replacement of the screen is located on page 18 in the HVAC service section.

Visual inspection of electrical connections, vents to HVAC ducting, and ducting tubing is recommended to verify that there are no loose connections, tears or obstructions that can impede maximum air delivery and HVAC performance.

7.2 Basic Functions

The default temperature shown on the display is the bunk temperature. Press UP (red triangle) or DOWN (blue triangle) arrow to adjust temperature set point on the display. When editing the set point, the LCD display will show the set point instead of bunk temperature, and the display will read Temp Edit. After adjusting the set point, press SELECT to save the new setting. The display will then revert back to the bunk temperature. If the system is already running, temperature changes may take a few seconds after the last UP or DOWN plus SELECT buttons are pressed. The system will remember the last temperature setting when the Dynasys unit is turned back on.

Press FAN button to enter the manual fan speed settings.

The FAN button cycles through the following fan options: FAN AUTO, FAN HIGH, FAN LOW and FAN OFF. Once the desired option is set, press SELECT to confirm. If the bunk temperature is different from the manual temperature set point, the air conditioning/heating will run when the fan speed is set and SELECT is confirmed. If the system was stopped by another method, the air conditioning/heating will start immediately when the system is restarted. The system will remember the last fan speed setting when the Dynasys is turned on.

7.3 Troubleshooting

This is a guide to assist in the proper diagnosis of issues that can affect HVAC performance. The Dynasys HVAC incorporates both 12VDC and 120VAC electrical systems. Only qualified individuals should perform these procedures.

Listed below are some simple checks that are designed to aid in the identification of a problem that may affect the performance of the HVAC box. For a more detailed diagnosis, refer to the flowcharts and electrical diagrams listed after this section.

NO HVAC FUNCTION QUICK CHECK

Does the control display Cool Mode?

If not, check to ensure that the temperature set point is below the ambient temperature in the bunk and the fan is on high, low or auto. If the settings are correct and the display still does not show "COOL MODE", then the control system needs to be reset. This is accomplished by powering down the unit and unplugging the 8 pin (J101) Molex connector from the ECM and leaving it disconnected for 15 seconds. After 15 seconds, plug the connector back in and retry the cooling functions. If this does not correct the display issue, refer to the troubleshooting guide for NO AC on pp 22-23.

Does the control display Heat Mode?

If not, check to ensure that the temperature set point is above the ambient temperature in the bunk and the fan is on high, low or auto. If the settings are correct and the display still does not show "HEAT MODE", then the control system needs to be reset. This is accomplished by powering down the unit and unplugging the 8 pin (J101) Molex connector from the ECM and leaving it disconnected for 15 seconds. After 15 seconds, plug the connector back in and retry the cooling functions. If this does not correct the display issue refer to the troubleshooting guide for NO HEAT on pp 24-25.



Is the HVAC blower operating?

If the blower is not operating, check the breakers at the Power Distribution box and at the APU. Reset, if required. If this does not restore blower function, refer to the troubleshooting flow chart and HVAC electrical diagram to verify proper input and output signals.

Is the condenser fan operating?

If not, check the fuse (located at condenser fan assembly in harness) and replace, if required. Verify condenser fan motor spins freely and is not binding due to debris or internal motor failure. Refer to the troubleshooting flow chart and HVAC electrical diagram for additional checks.

Is there 120 VAC power at the convenience outlets?

Note: the convenience outlets have a built-in breaker (GFCI). Ensure that it is reset. Next check the breaker on the Power Distribution Box and reset if required. If this is OK check the main 60 AMP breaker located at the rear of the APU. Finally check that the main connectors at the APU are properly connected. If there still is no 120 VAC power, refer to the "No 120 VAC Power" troubleshooting guide.

Is the refrigerant charge correct?

If the condenser fan and blower are on and the display is showing COOL MODE, check the refrigerant charge with proper gauges. If the charge is low, check the system for leaks. If a leak is found at the hoses, fittings or condenser, replace or repair. If a leak is found in the HVAC box at a threaded fitting or switch, it can be tightened and/or the o-ring replaced and re-tightened. If a component is identified as leaking or needing replacement, refer to the service replacement section. Use an approved UL leak detector to perform the leak check function.

NO 120VAC POWER QUICK CHECK

Check that breakers at the Power Distribution box are not tripped. Reset, if necessary.

Check that cable connections at the Power Distribution box are secure.

Check that the main breaker at the rear of the APU is not tripped.

Check that the cable connectors at the rear of the APU are secure.

Check Voltage at APU. Disconnect the 120 VAC cables at the rear of the APU. (Before disconnecting, make sure the APU is not running.) Restart the APU and check for 120 VAC at the connectors. The actual voltage measured may vary between 110-130 volts.

If there is 120 VAC at the connectors and the connectors fit securely together, there may be a fault in the cable or connectors. Check the cables for damage.

Check the belt/drive system. With the APU operating, confirm that the main drive belt is driving the generator shaft. Remove the right lower side panel behind the tailpipe to provide access to the rear of the generator. Shaft motion can be detected by observing the generator rotor through the plastic ventilation cover on the rear of the generator.

If the generator shaft is not turning, ensure that the main drive belt is intact and engaged with all pulleys. Replace if necessary. (If the belt has been thrown from the pulleys, there may be a problem with either the belt tensioner or belt alignment.)

Check for 120 VAC across the leads from the generator. This can be done by attaching a volt meter across the 120VAC supply side at the input terminal of the main breaker and the 120 VAC common lead at the power connector.

If the measured voltage does not fall within the range specified above, replace the generator capacitor (found behind the plastic ventilation cover). If replacing the capacitor does not solve the problem, replacement of the generator may be required.

Note: the convenience outlets have an additional breaker (GFCI) located in the center of the outlets. Ensure that it is reset.

SHORE POWER Quick Check (Optionally installed item)

Most issues with unsatisfactory performance of the shore power unit are a result of using too long of a power cord or too small of a gauge wire. Hodyon recommends that a maximum length of 50ft be used with a minimum wire gauge of 12 AWG.

The shore power system must be operated on a dedicated 15 amp circuit to prevent nuisance tripping of the breaker.

Intermittent starting of the APU, while connected to shore power is usually a result of an improper setting of the Low Battery Auto-Start feature.

NOTE: With the optional Shore Power Kit installed, only HVAC operation is possible. Convenience outlets and Engine Block Heater power are disabled.

74 HVAC Service Procedures

HVAC Inlet Filter Screen Service

Inlet screen is attached to the front of evaporative core with 4 white push pins located at each corner. Remove the pins and carefully slide screen edges away from HVAC box assembly. Cleaning of the screen can be achieved by either shaking dust and debris off or rinsing under low pressure, warm water. Reinstall screen after thoroughly drying, with attention being given to the re-installation of the screen edges. The screen should be inspected on a monthly basis.



1 - Filter Screen

HVAC Evaporative Core / Expansion Valve Service

1. Disconnect power sources to HVAC assembly.
2. Remove HVAC top covers.
3. Recover refrigerant using approved UL equipment.
4. Remove Inlet Screen.
5. Remove #10 suction line at upper connection of expansion block.
6. Remove #6 bulkhead hose fitting at lower connection of expansion block.
7. Remove expansion block through bolt.
8. Removal of core is achieved by sliding core assembly backwards and lifting out of HVAC box.
9. Remove expansion block from core assembly.
10. Reverse procedure to complete reinstallation ensuring all o-rings are in place and undamaged.
11. Perform leak check and performance check prior to releasing unit to owner/operator.

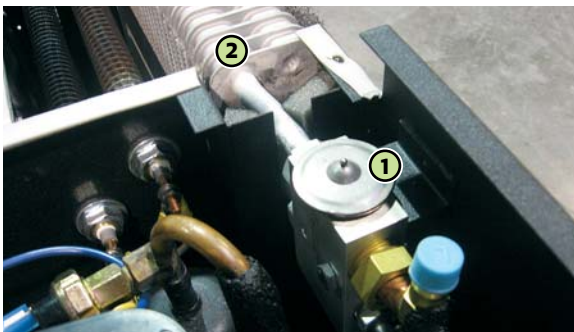

1: Expansion Valve 2: Evaporator

Compressor Assembly Service

1. Disconnect power sources to HVAC assembly.
2. Remove HVAC top covers.
3. Recover refrigerant using approved UL equipment.
4. Remove #10 suction line at upper connection of expansion block.
5. Remove #8 discharge fitting at upper connection of compressor assembly and hose support clamp.
6. Remove compressor top electrical cover.
7. Disconnect the 3 electrical wires at compressor top, noting proper wire color location for reinstallation.
8. Remove the 3 compressor mounting nuts at lower compressor flange.
9. Remove compressor assembly from HVAC.
10. Reverse procedure to complete reinstallation ensuring all o-rings are in place and undamaged.
11. Perform leak check and performance check prior to releasing unit to owner/operator.



1 - Compressor

HVAC PCB Service

1. Disconnect power sources to HVAC assembly.
2. Remove HVAC top covers.
3. Recover refrigerant using approved UL equipment.
4. Remove #10 suction line at upper connection of expansion block.
5. Remove #8 discharge fitting at upper connection of compressor assembly and hose support clamp.
6. Remove compressor top electrical cover.
7. Disconnect the 3 electrical wires at compressor top, noting proper wire color location for reinstallation.
8. Remove the 3 compressor mounting nuts at lower compressor flange.
9. Remove compressor assembly from HVAC.



10. Remove electrical connections from PCB assembly, taking note of all connections for proper reinstallation.
11. Reverse procedure to complete reinstallation ensuring all o-rings are in place and undamaged.
12. Perform leak and complete performance check prior to releasing unit to owner / operator.

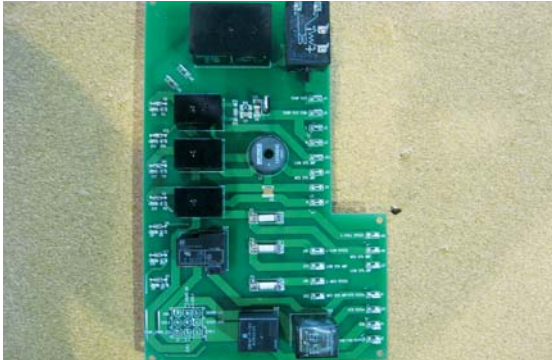

HVAC Printed Circuit Board

Heater Element Service

1. Disconnect power sources to HVAC assembly.
2. Remove HVAC top covers.
3. Recover refrigerant using approved UL equipment.
4. Remove #10 suction tube at upper connection of expansion block.
5. Remove #8 discharge fitting at upper connection of compressor assembly and hose support clamp.
6. Remove compressor top electrical cover.
7. Disconnect the 3 electrical wires at compressor top, noting proper wire color location for reinstallation.
8. Remove the 3 compressor mounting nuts at lower compressor flange.
9. Remove compressor assembly from HVAC.
10. Remove electrical connections at the 1.0kw or 1.5kw heater element, noting wire color location for proper reinstallation.
11. Remove heater elements and retain all hardware for reinstallation. NOTE- heater element location is critical for proper operation. The 1.5kw element is located closer to the blower motor cavity of HVAC box.
12. Reverse procedure to complete reinstallation ensuring all o-rings are in place and undamaged.
13. Perform leak and complete performance check prior to releasing unit to owner / operator.

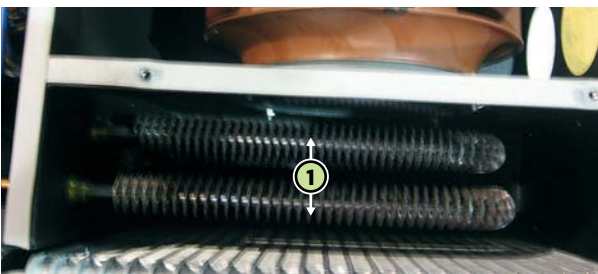

1 - Heater Elements

Blower Motor Service

1. Disconnect power sources to HVAC assembly.
2. Remove HVAC top covers.
3. Recover refrigerant using approved UL equipment.
4. Remove #10 suction line at upper connection of expansion block.
5. Remove #8 discharge fitting at upper connection of compressor assembly and hose support clamp.
6. Remove compressor top electrical cover.
7. Disconnect the 3 electrical wires at compressor top, noting proper wire color location for reinstallation.
8. Remove the 3 compressor mounting nuts at lower compressor flange.
9. Remove compressor assembly from HVAC.
10. Remove electrical connections at 1.0kw and 1.5kw heater elements, noting wire color location for proper reinstallation.
11. Remove heater elements and retain all hardware for reinstallation. NOTE- heater element location is critical for proper operation. The 1.5kw element is located closer to the blower motor cavity of the HVAC box.
12. Remove blower motor cone, retain hardware for reinstallation.
13. Remove blower motor electrical connections at PCB assembly, ground lug and capacitor, noting proper wire location for reinstallation.
14. Remove the 4 blower motor assembly screws at outer face of HVAC box, retain for reinstallation.
15. Remove blower motor and cone assembly from HVAC box.
16. Reverse procedure to complete reinstallation ensuring all o-rings are in place and undamaged.
17. Perform leak and complete performance check prior to releasing unit to owner / operator.

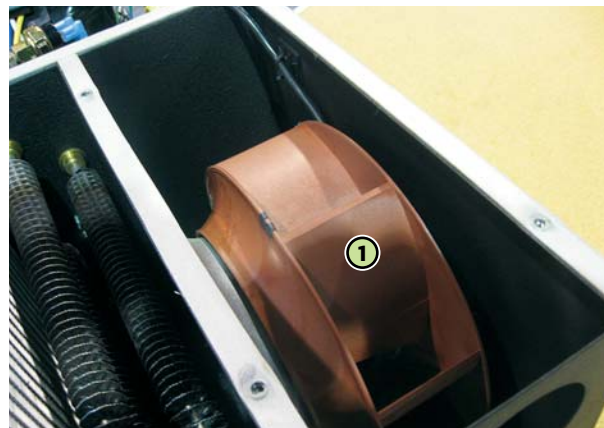

1: Blower Assembly

Compressor Run / Start Capacitor Service

1. Disconnect power sources to HVAC assembly.
2. Remove HVAC top covers.
3. Recover refrigerant using approved UL equipment.
4. Remove #10 suction line at upper connection of expansion block.
5. Remove #8 discharge fitting at upper connection of compressor assembly and hose support clamp.
6. Remove compressor top electrical cover.
7. Disconnect the 3 electrical wires at compressor top, noting proper wire color location for reinstallation.
8. Remove the 3 compressor mounting nuts at lower compressor flange.
9. Remove compressor assembly from HVAC.
10. Remove desired capacitor from holder located at left rear corner of compressor assembly cavity of HVAC box, noting wire location for proper operation.
11. Reverse procedure to complete reinstallation ensuring all o-rings are in place and undamaged.
12. Perform leak and complete performance check prior to releasing unit to owner / operator.



1 Capacitors

Condenser Assembly Service

1. Recover refrigerant using approved UL equipment.
2. Remove #6 and #8 hose fittings from assembly.
3. Remove the 6 (total) condenser shroud bolts located at the flange areas of shroud. It is recommended to remove the lower 3 first; Retain hardware for reinstallation.
4. Remove the condenser assembly from the shroud.
5. Reverse procedure to complete reinstallation ensuring all o-rings are in place and undamaged.
6. Perform leak and complete performance check prior to releasing unit to owner / operator.



1 Condenser Assembly

Receiver Drier Service

1. Recover refrigerant using approved UL equipment
2. Remove both #6 hose fittings from drier bottle assembly.
3. Loosen drier bottle clamps.
4. Remove drier from condenser shroud assembly.
5. Reverse procedure to complete reinstallation ensuring all o-rings are in place and undamaged.
6. Perform leak and complete performance check prior to releasing unit to owner / operator.

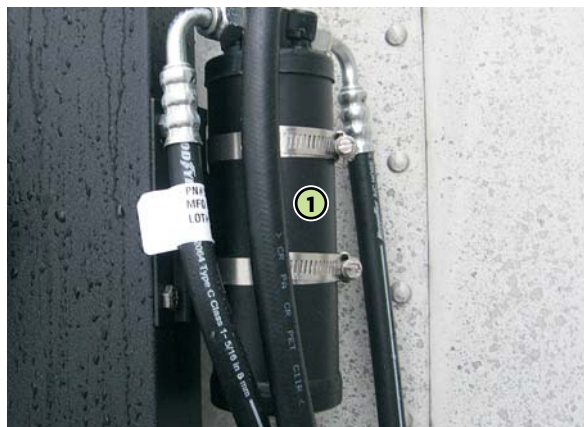

1 Receiver Drier



7.5 Troubleshooting Flow Charts

Engine Won't Start

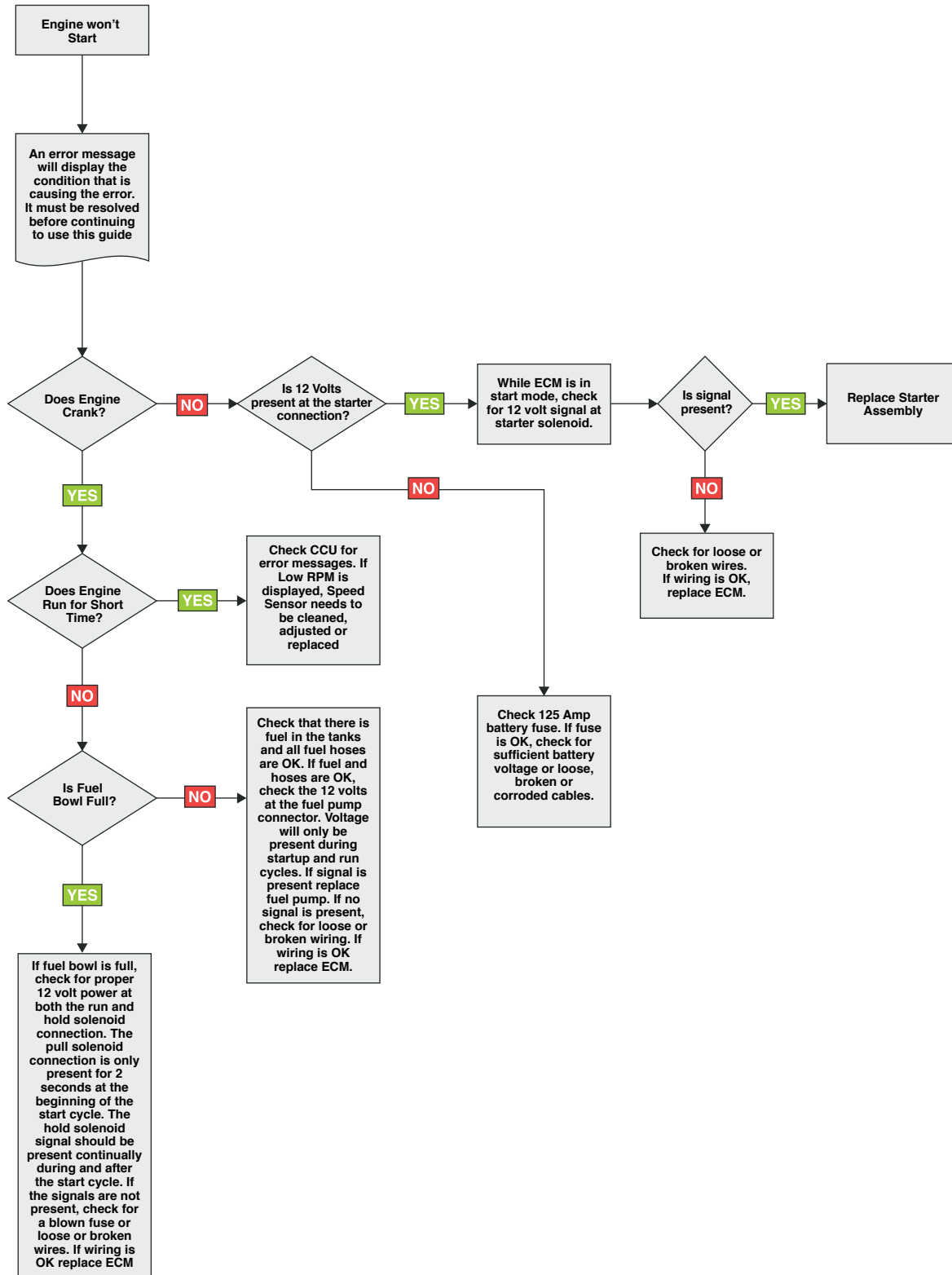

► **No Air Conditioning**

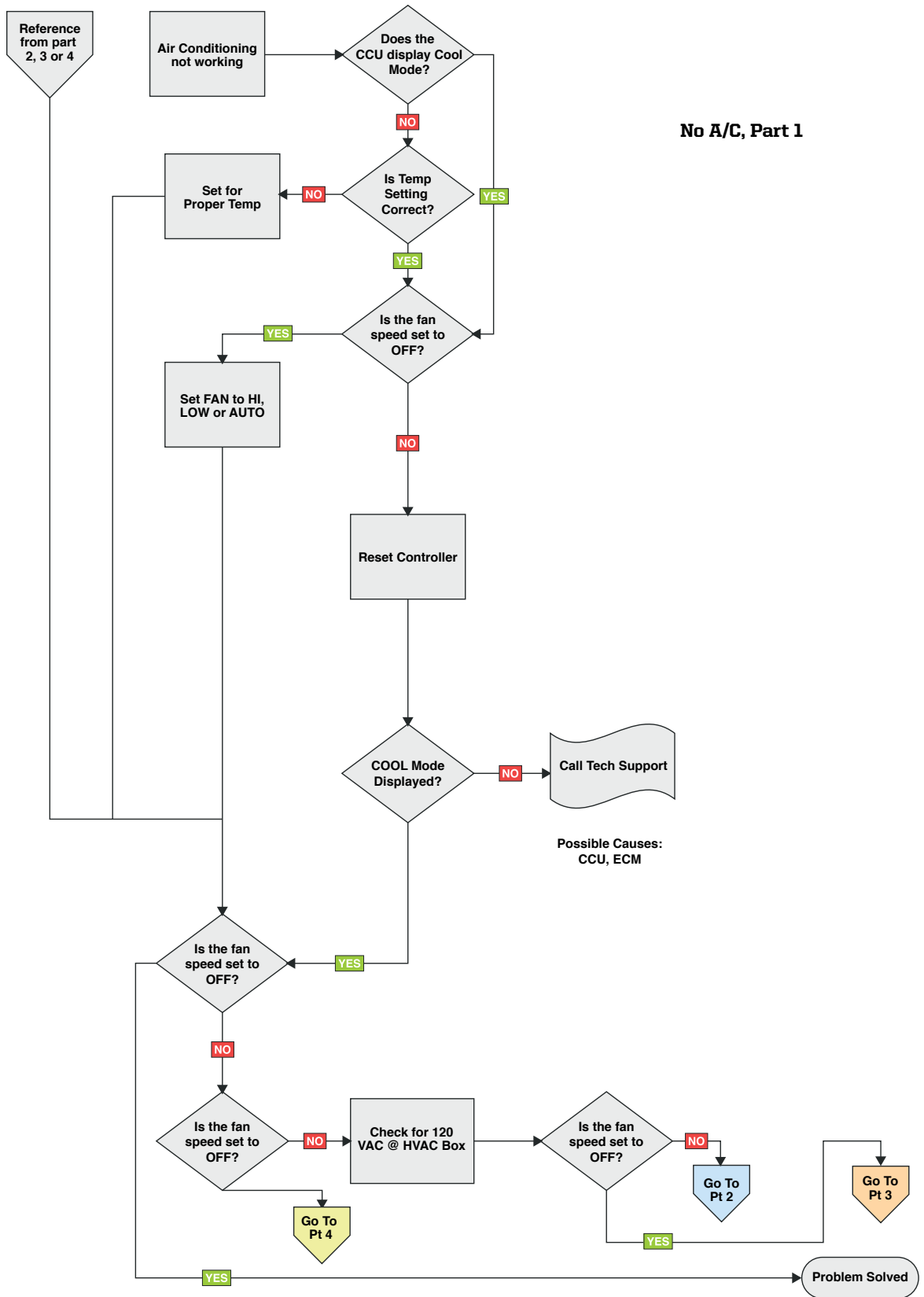

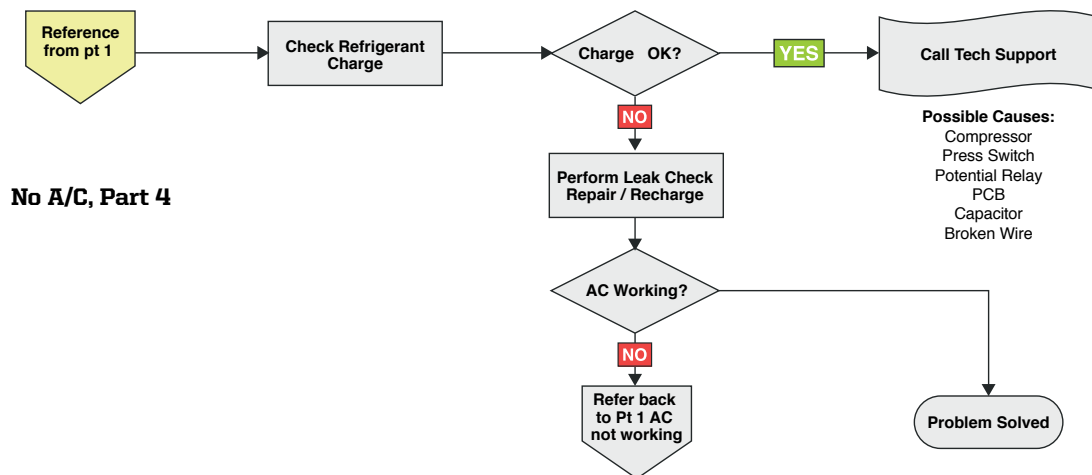
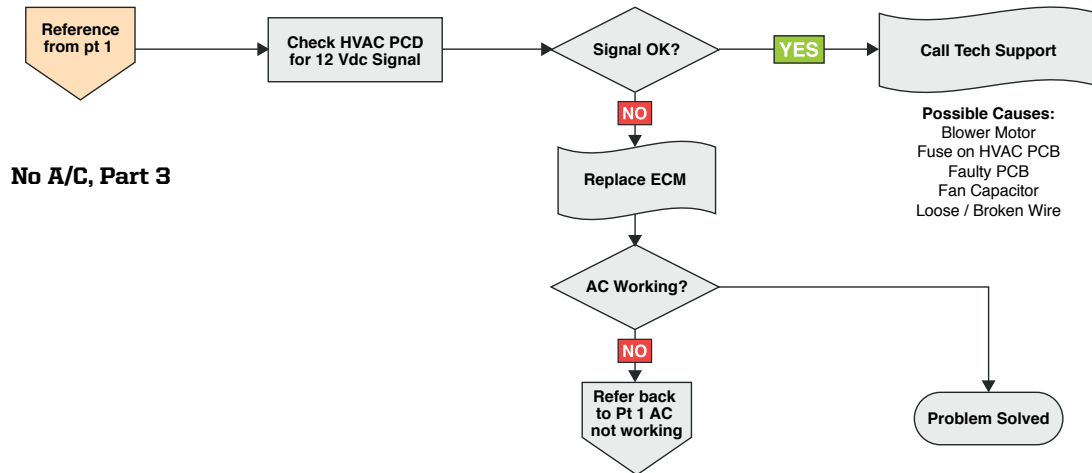
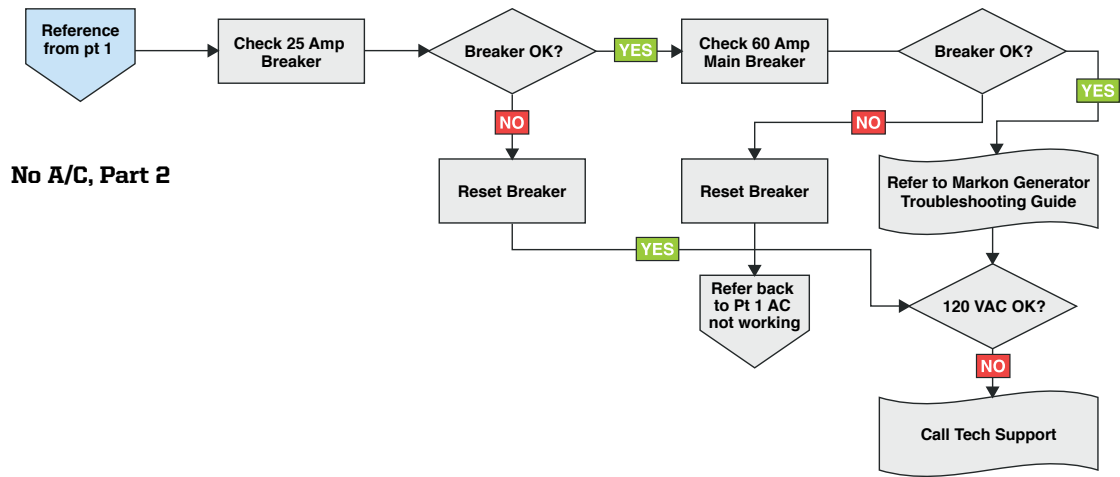

► **Heater Not Working**

Heater Not Working, Part 1

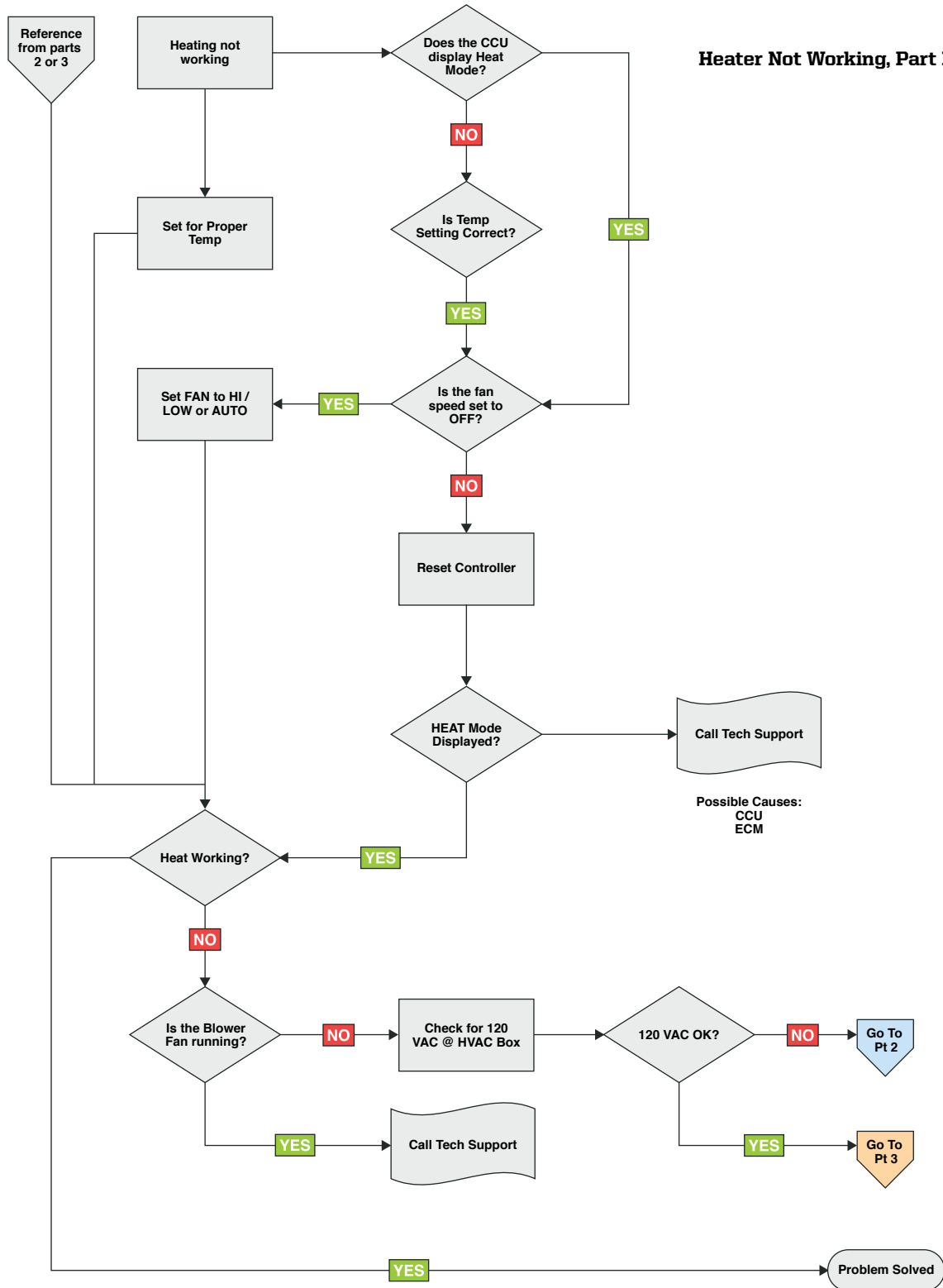

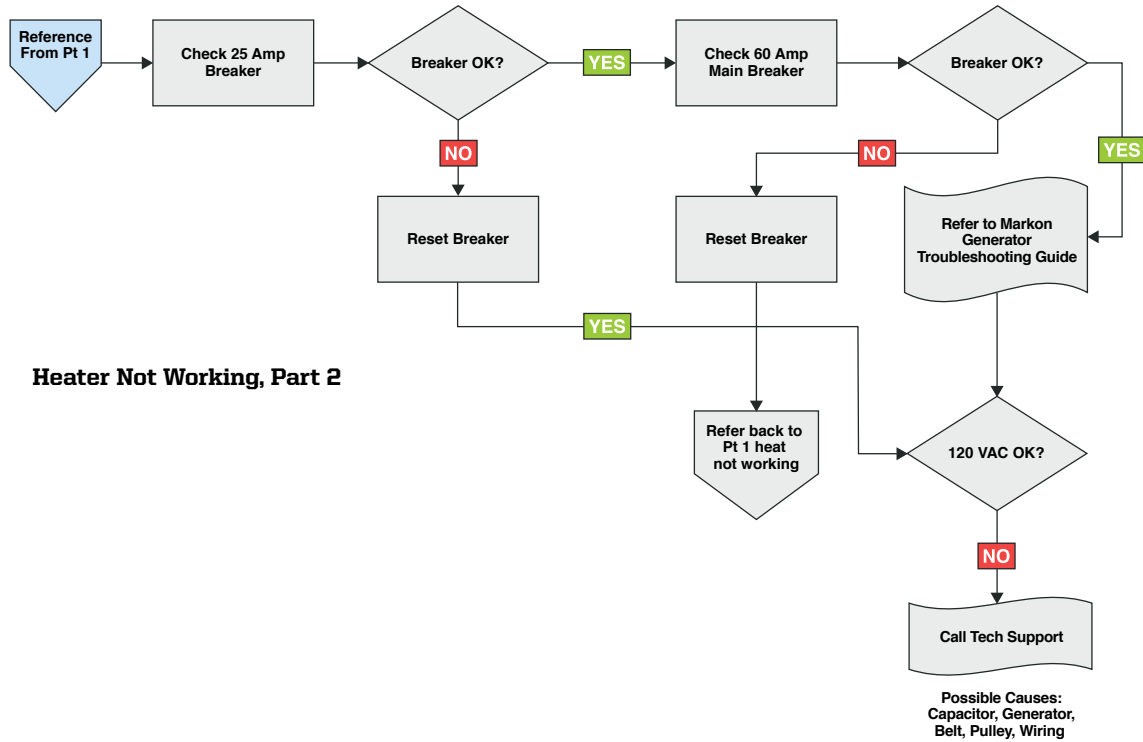

Heater Not Working, Part 2

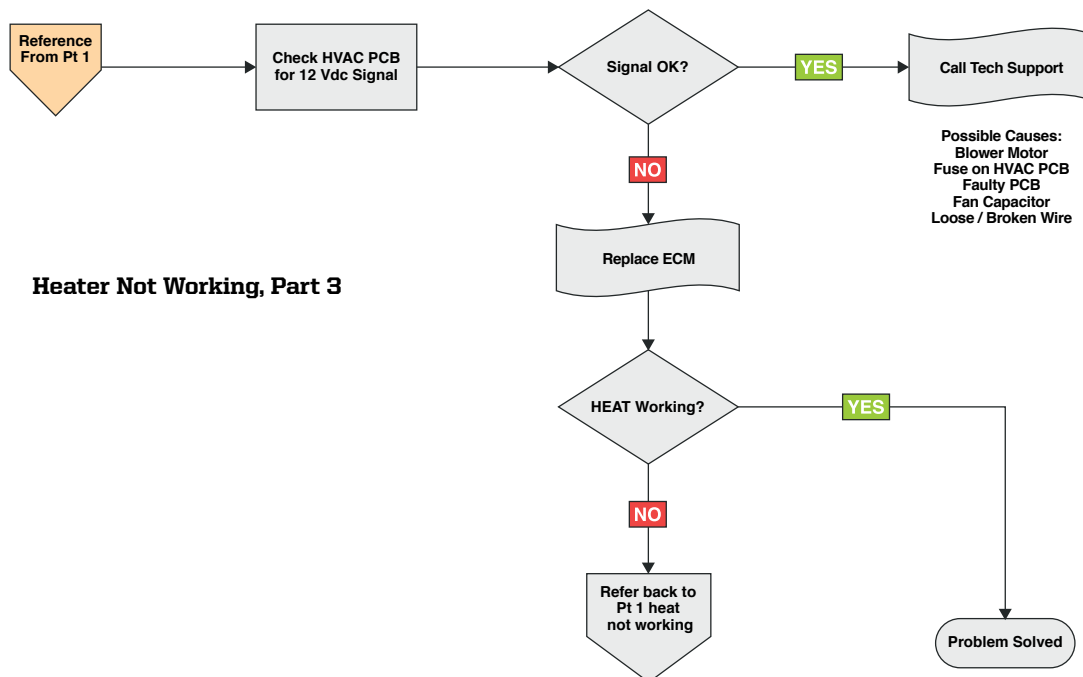

Heater Not Working, Part 3

► No Generator Output

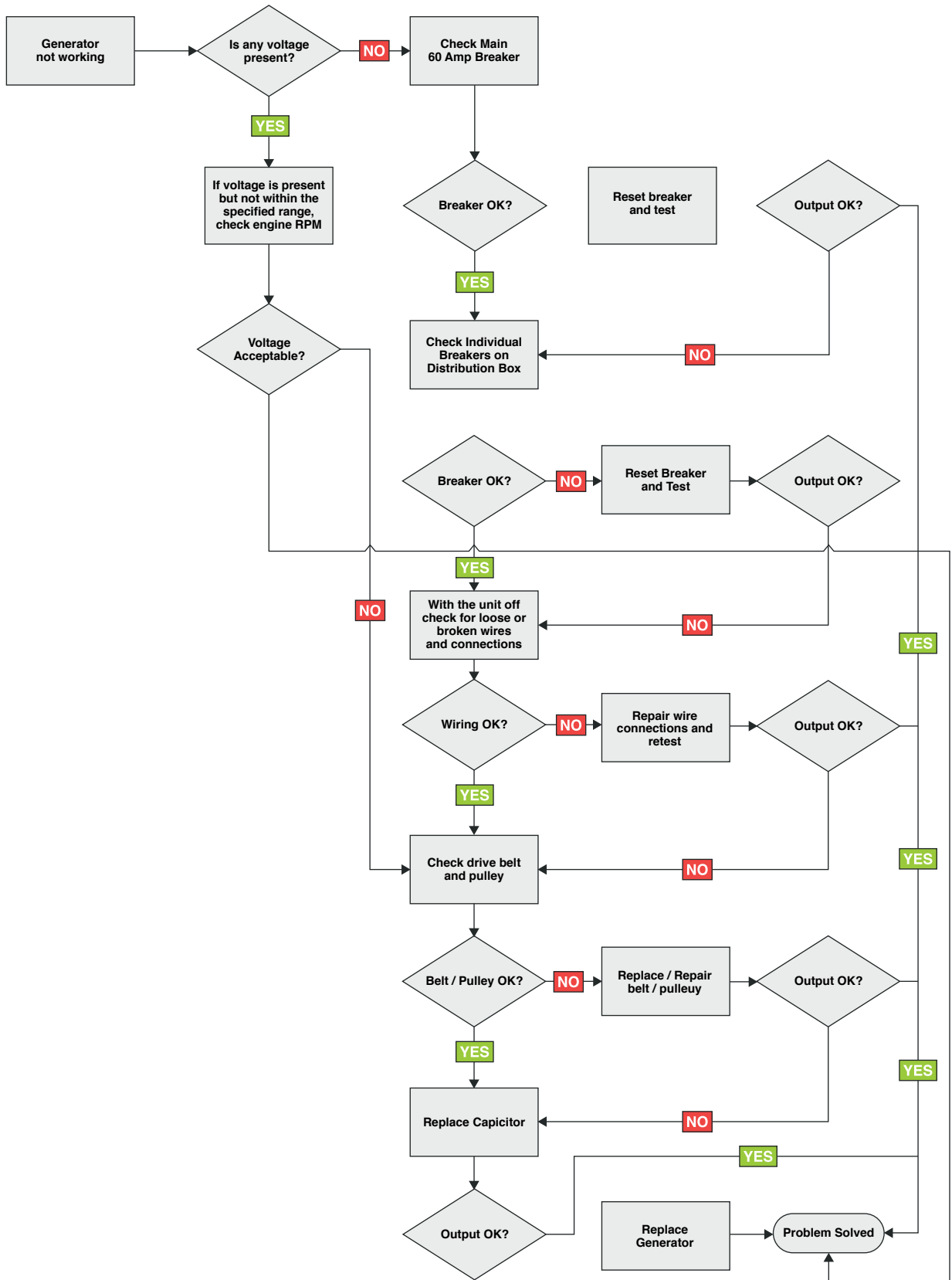

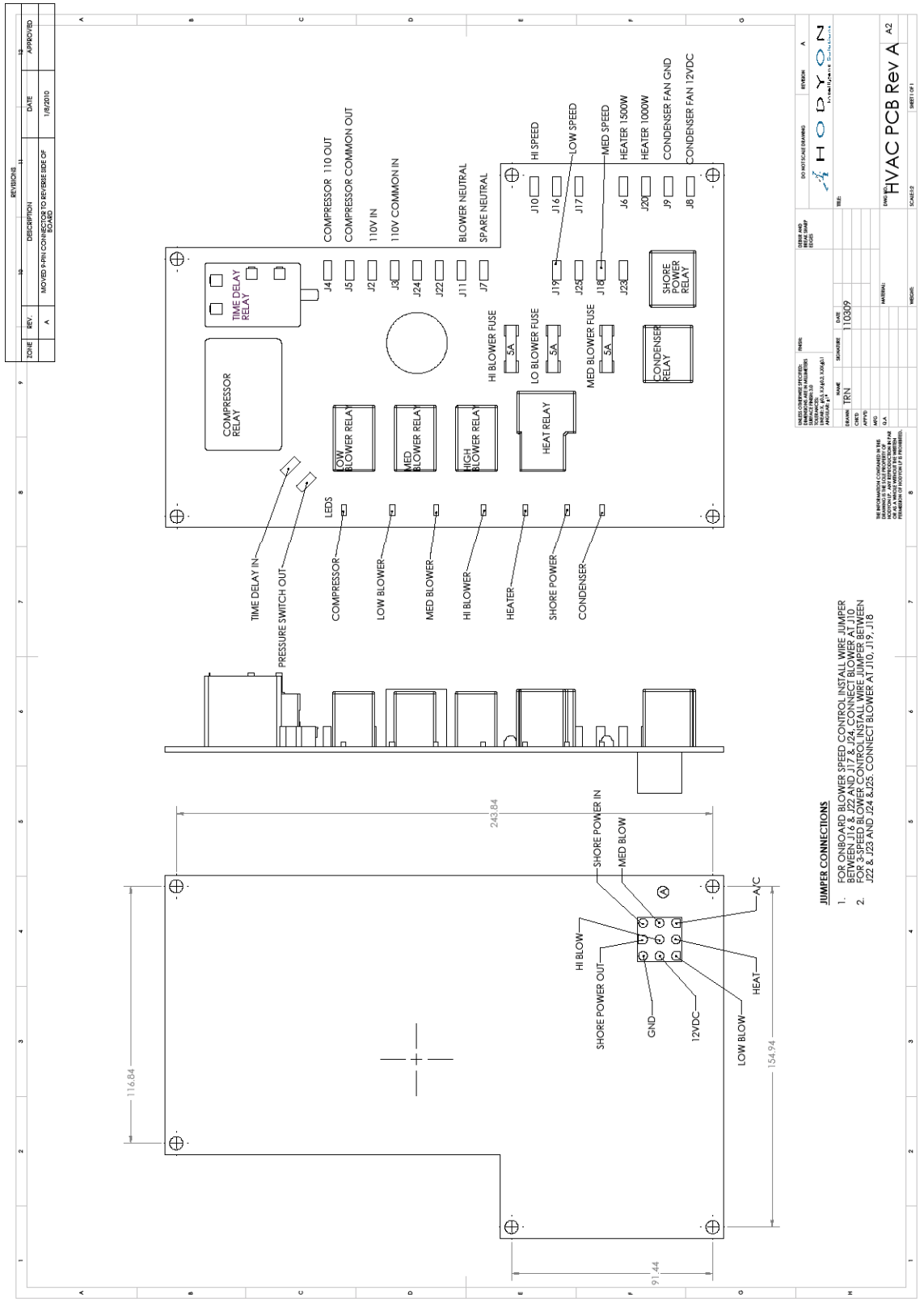

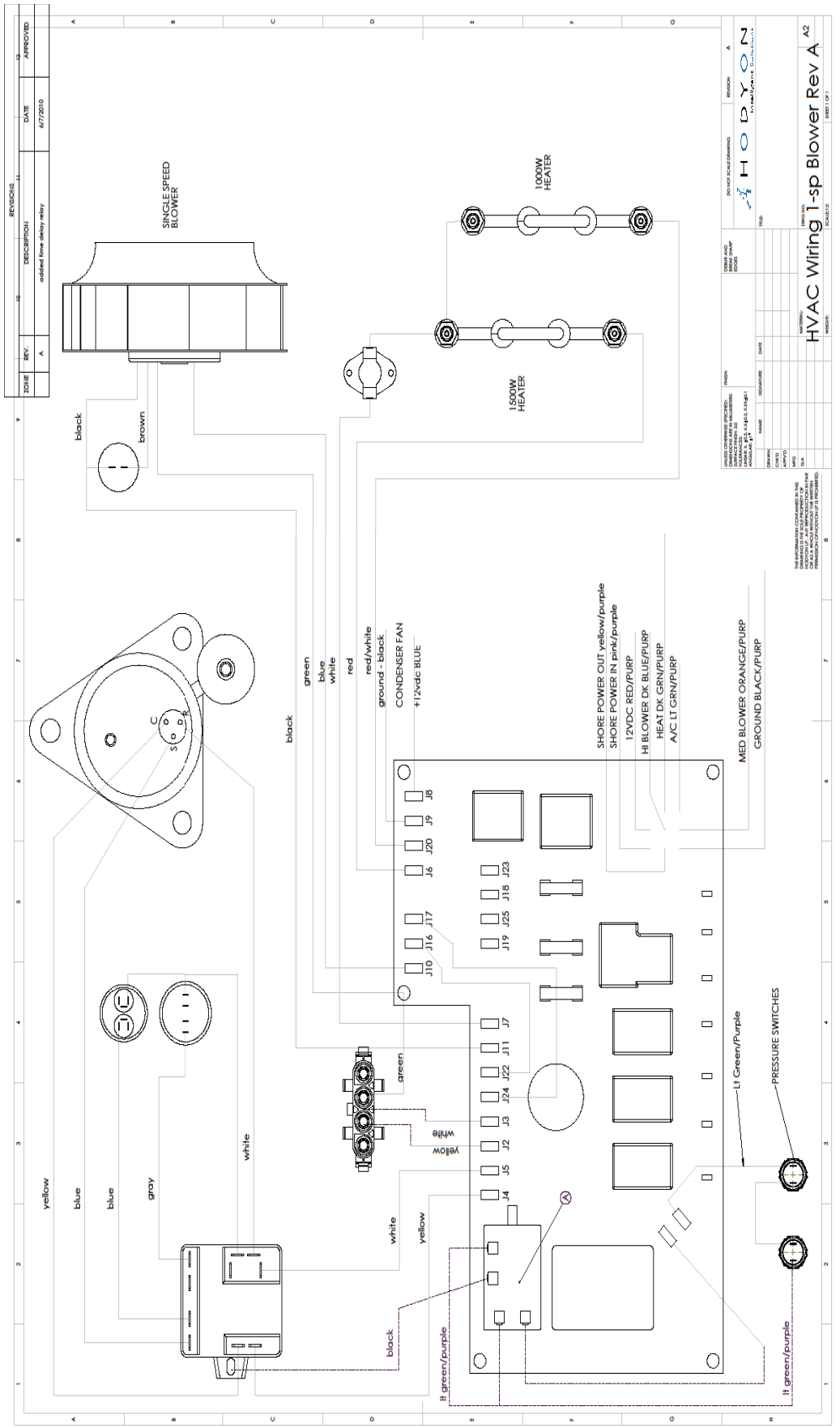

NO.	REV.	DESCRIPTION	DATE	APPROVED
1	A	added time safety relay	4/7/2010	

DESIGN AND CHECK SHEET

DESIGNER: **H O D Y N**

DATE: _____

SCALE: _____

PROJECT: HVAC Wiring 1-sp Blower Rev A

REV: A2

SHEET 1 OF 1



Notes:

A series of horizontal dashed lines for taking notes.



120 East Old Settlers Boulevard
Round Rock, TX 78664-2248

www.hodyon.com
512.225.0165